

# USER'S MANUAL HAKI COMPACT STAIR TOWER

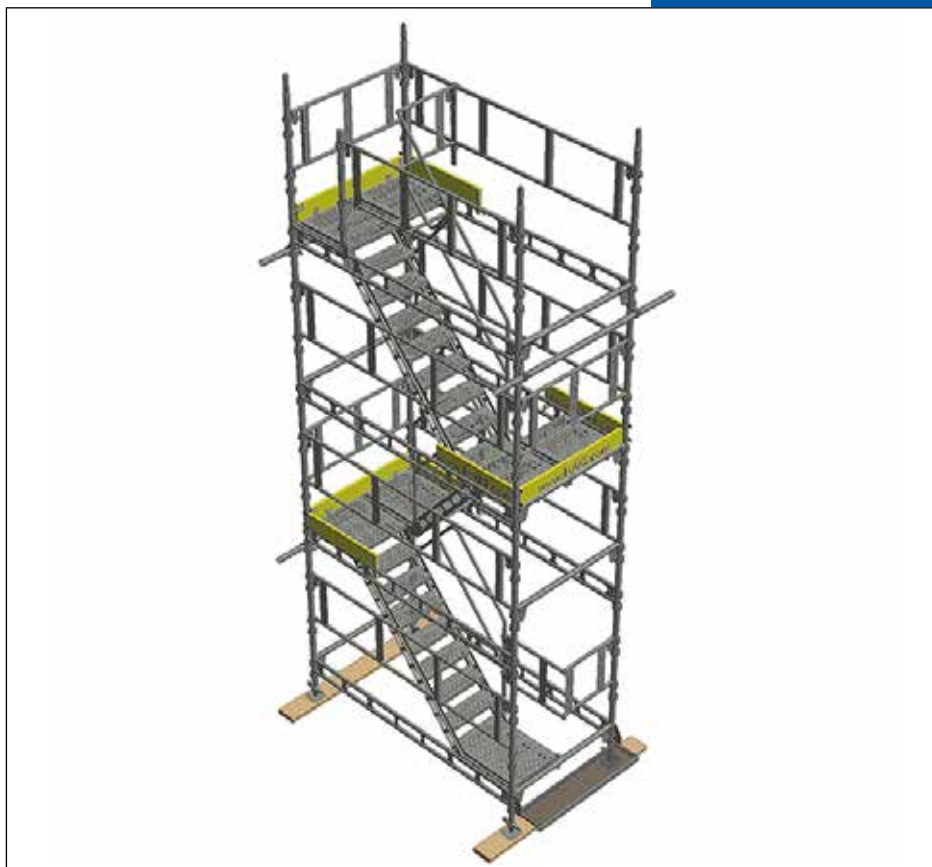

## Important information

HAKI's product liability and user's manuals apply only to scaffolds that are entirely composed of components that have been made and supplied by HAKI.

HAKI's scaffold systems must not be erected using components of makes other than HAKI or be connected to scaffolds of makes other than HAKI. In such cases, a special study of load-bearing capacity must be carried out. However, HAKI has no objection to the customary addition of scaffold tubes and approved couplers to the scaffold.

Adding components from different suppliers may invalidate the insurance cover.

This user's manual is based on a minimum of 2 competent erectors wearing work restraint Twin Tool lanyards of fixed length of 800 mm (including fittings).

This user's manual is to be used in conjunction with HAKI training courses.

A user's manual should be provided to the user together with the scaffolding.















HAKI reserves the right to make technical modifications on a continual basis.

The latest versions of HAKI user's manuals can be downloaded from our website, [www.HAKI.com](http://www.HAKI.com).

For scaffold structures that are not covered by this user's manual, please contact HAKI's technical department.

## HAKI colour code

Horizontals and diagonals are marked with their nominal sizes (bay sizes) and a colour code. The marking is a useful means of identification when erecting and handling the scaffold material.

564 	1050 	1964 	3050 
700 	1250 	2050 	3650 
770 	1550 	2500 	4050 
1010 	1655 	2550 	

## Forces and dimensions

1000 N = 1 kN ~ 100 kg

10 N ~ 1 kg

All measurements in mm

© Copyright HAKI AB, 2018

The reproduction of text and pictures/illustrations without HAKI's permission is prohibited.

## **HAKI Compact Stair Tower**

All HAKI Systems have been designed to conform to current British and European Standards. The loading criteria contained in this manual have been calculated according to current European Standards, SS-EN 12810 and SS-EN 12811.

### **General**

The Compact Stair Tower is made from pre-fabricated components for Light Duty Applications. All components are hot-dip galvanized. The HAKI Compact Stair Tower consists of HAKI Universal base jacks, standards, beams, diagonal braces and guardrails.

Other components that are designed specifically for Compact Stair Towers include stair flights, landings, handrails, toeboards, etc.

Compact Stairs are erected with bay widths of 1250mm, bay lengths of 2500mm and with 1500mm between lifts. It can be erected both as a separate construction or integrated into other scaffolding or staging.

### **Marking**

All components with the exception of locking catches, locking pins, etc. come permanently marked with the HAKI logo and the last two figures of the year of manufacture (e.g. S18).

All load bearing components are marked for full traceability.









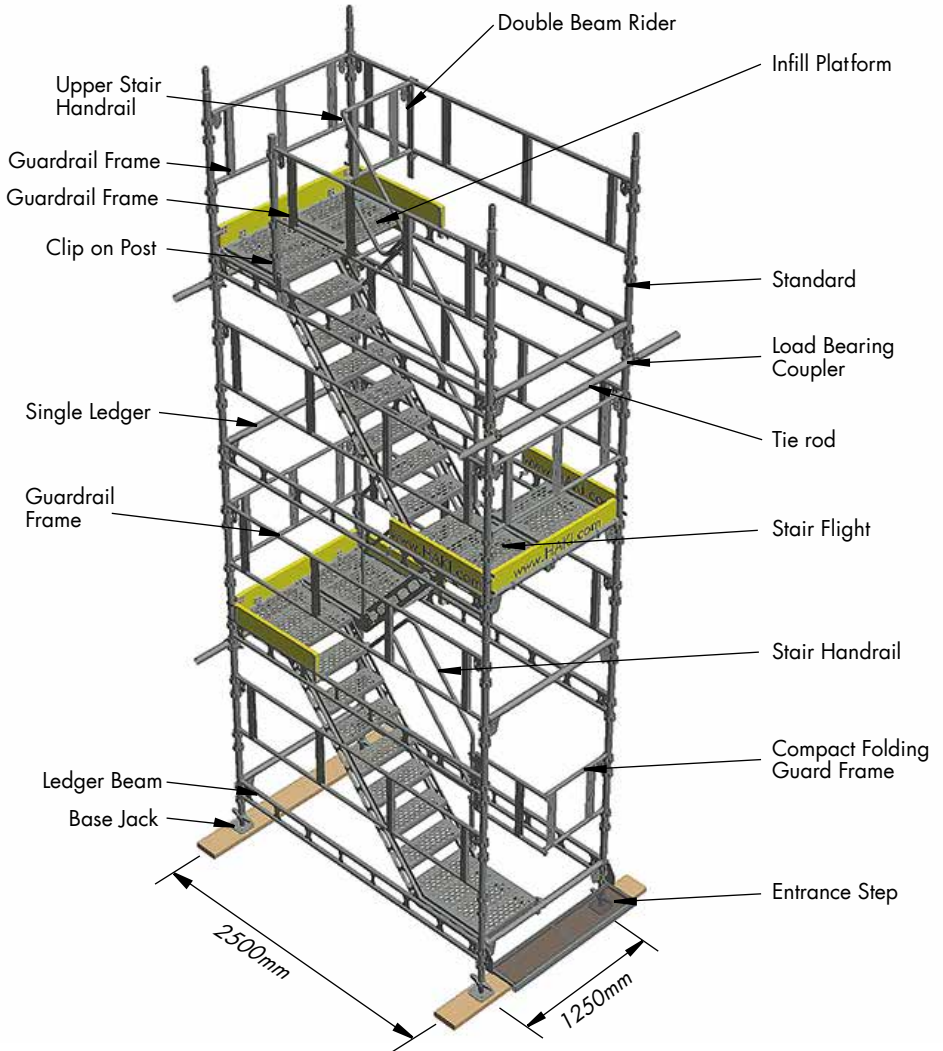





### **IMPORTANT**

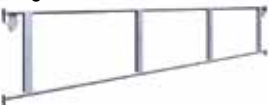





**ENGAGE LOCKING CATCHES AS EACH  
COMPONENT IS FIXED**





Name	Code/Data	Item No.	Weight(kg)
<b>Base Jack BS</b> Adjustable 55-570 mm 		<b>2071000</b>	5.0
<b>Standard S</b> Standard joint with spigot Pockets at same level Ø48 mm 	500 1000 1500 2000 3000	<b>7016050</b> <b>7016100</b> <b>7016150</b> <b>7016200</b> <b>7016300</b>	2.9 5.3 7.7 10.1 15.2
<b>Locking Pin</b> Steel Ø 16 mm 		<b>2116000</b>	0.2
For reinforcing standard joint in connection with tensile load, e.g. when scaffolding is suspended, when lifting or when scaffolding is used for temporary roof. 		<b>5141257</b>	0.3
<b>Ledger beam LBL</b> With spring locking catch Ø 34 mm 	1250 2500	<b>7021222</b> <b>7021252</b>	6.5 10.9
<b>Single Ledger ERB</b> With spring locking catch Ø 48 mm 	1250 2500	<b>7022121</b> <b>7022246</b>	5.1 8.9
<b>Guardrail Frame GFL</b> With spring locking catch 	1250 1890 2500	<b>7052124</b> <b>7052185</b> <b>7052254</b>	5.7 7.9 9.2
<b>Entrance Transom</b> 	1250	<b>7104120</b>	5.3
<b>Compact Transom Spacer</b> 		<b>7058258</b>	0.6

Name	Code/Data	Item No.	Weight(kg)
<b>Double beam Rider</b> For guardrail frame or ledger beams With locking screw N=21		<b>7208033</b>	2.4
			
<b>Entrance Step ITR</b>	1250	<b>7103120</b>	11.1
			
<b>Infill Platform</b>		<b>7095002</b>	12.5
			
<b>Compact Folding Guardframe</b>		<b>7053006</b>	6.7
			
<b>Upper Stair Handrail STC</b> For top level		<b>7058252</b>	6.9
			
<b>Stair Handrail HL</b>	1500	<b>7058261</b>	8.6
			

Name	Code/Data	Item No.	Weight(kg)
<b>Stair Flight STC</b> 	1500	<b>7101250</b>	41.0
<b>Guardrail post SS</b> For erection on Ledger Beam LBL 	1000	<b>7015000</b>	6.1
<b>Toeboard AL</b> 	1250 2500	<b>4161121</b> <b>4161201</b>	2.2 4.3
<b>Toeboard</b> 	873 1250	<b>2025085</b> <b>2025119</b>	3.2 4.3
<b>Light Deck/Erection Platform AL</b> 	1250x600	<b>4071122</b>	10.6
<b>Advanced Guardrail Tool AL</b> 		<b>4052001</b>	1.4

For other accessories, see HAKI Component List.

## **Information on safety when erecting and dismantling**

1. Carry out local risk assessment and method statement.
2. Make sure that all lifting equipment to be used, e.g chain hoists, lifting ropes, pulley blocks, etc., has been thoroughly tested and approved by an authorised person in accordance with local regulations.
3. Check that tools and protective equipment are available at the worksite.
4. Wear appropriate personal safety equipment at all times, e.g safety harnesses, proper independence lifelines with suitable fixings, etc.
5. When erecting and dismantling a scaffold, robust temporary decking must be used as temporary platforms for the scaffolders.
6. Always make sure that the safety locking devices that prevent a platform lifting off have been activated once a platform has been installed.
7. Study all relevant instructions or safety directions from the manufacturers of the various scaffolds that are to be used.
8. Never climb up a scaffold from the outside. Always use the stairs, ladders or climbing frames that are designed to provide access to the upper decks from the inside of the scaffold.
9. If the scaffold is to be used outdoors, erection or dismantling work must be discontinued if the weather conditions are severe. Make sure that all loose components are properly fixed before leaving the scaffold.
10. Scaffolding work must be done by “competent operatives” under the supervision of a “competent person”.
11. Lifting equipment must not be attached to a free-standing scaffold.
12. Beware of any overhead power lines nearby.
13. Always observe and comply with the regulations issued by the local authorities concerned.
14. Erectors/dismantlers should always be clipped to a single ledger or ledger beam during erection/dismantling. Reference should also be made to section “Personal Safety Equipment” in the Universal User manual.





Note: This erection procedure will result in a minimum height of 1.9m for the first exit point due to the distance between the first lift and the ground. If a lower first exit point is required, refer to the alternative erection procedure on page 14 in this manual.

Before erecting the tower, check and flatten out the ground. The ground must be flat for even settlement of the base lift. The ground's bearing capacity may be improved with the help of sole pads.

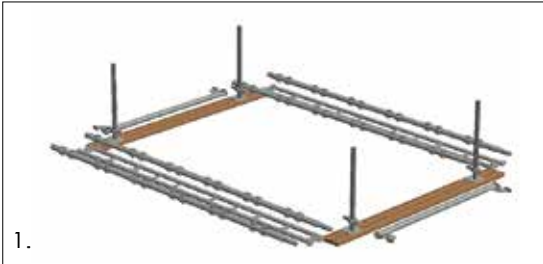

**1.** Lay out material to form base lift.

Position base jacks on sole pads, in approximate position of standards.

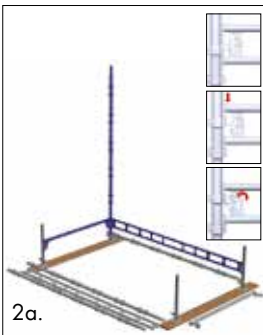

**2a.** Install the first standard and fit a 1250mm single ledger and a 2500mm ledger beam to it.

The beams are fitted to the lowest group of pockets on the standard.

Lock the beams into position.

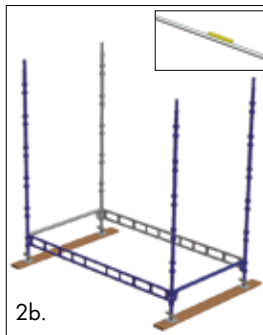

**2b.** Install standards, transoms and beams in order to complete the first lift.

Note: Check the levels in both the transverse and longitudinal directions using a spirit level and adjust using the base jacks. If necessary, fit a plan brace in order to ensure that the stair is square.



**3a.** Install a single ledger and two ledger beams 3 sets of pockets above the first lift (1500mm). This will be the first exit point. For the entrance point, fit a 1250mm guardrail frame 5 sets of pockets above the first transom (2000mm).

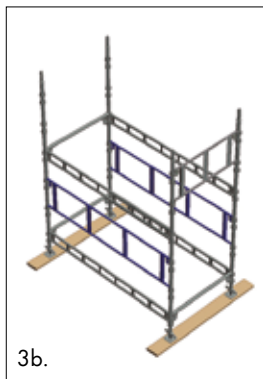

**3b.** Install 2500mm guardrail frames (GFL) at the lowest levels. The installed GFLs correct the vertical alignment of the standards.

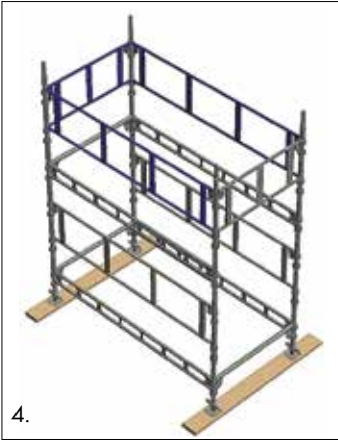

**4.** Install guardrail frames around all 4 sides of the tower at the same level as the entrance guardrail frame.

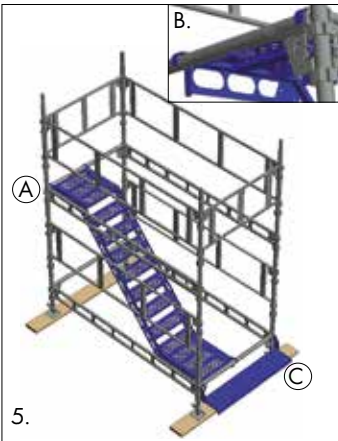

**5.** Install first stair flight A onto the transom units.

B. Lock stair to transoms.  
Install an entrance step C for easy access to the lowest lift. (No entrance step required when using the alternative erection procedure).



**6.** Install internal handrail into holes in the stringer of the stair flight as shown in A. Slide the handrail down until locking plate is at bottom of the hole as shown in B and then tighten the four nuts.

Install infill platform C and lock onto transom.

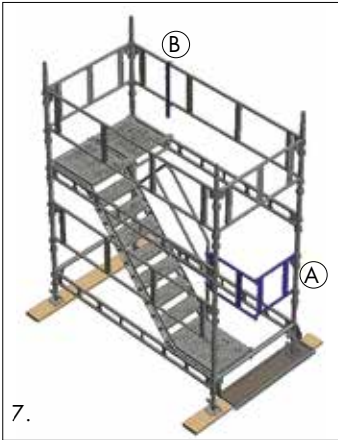

**7.** Install a compact folding guardrail frame A to stair handrail and standard on the lowest landing.

Install double beam rider B on the guardrail frame.

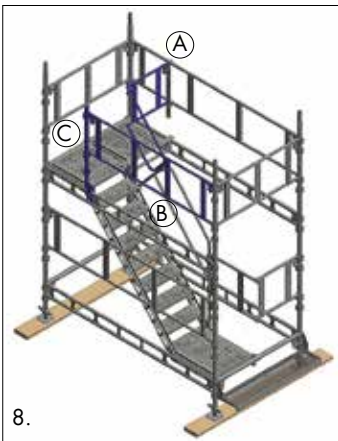

**8.** Install upper stair handrail A to double beam rider and stair handrail. Tighten all securing nuts.

Remove the 2500mm guardrail frame and fit a 1890mm guardrail frame B to standard in its place.

Install clip on post C and connect to opposite end of 1890mm guardrail frame.

**NOTE:** Do not remove the 2500mm guardrail frame if a subsequent lift is going to be installed. Tie tower and continue onto step 10.

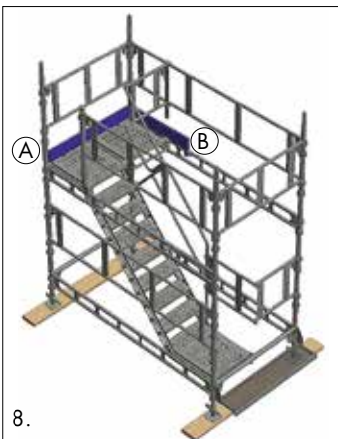

**9.** Install toeboards A&B.

Tie tower to adjoining structure using T&F. Tie pattern on page 17 in this manual.

The first lift is now complete.

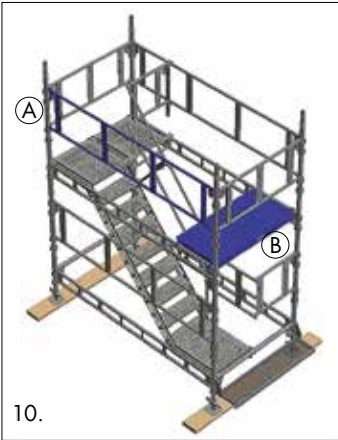

**10.** To work on the next lift, remove the 1890mm guardrail frame and the clip on post. Install 2500mm guardrail frame A in their place.

Remove toeboards. Wherever possible, position temporarily removed items onto side scaffold. Position erection platform B at first lift.



**11.** Install the next set of 1500mm standards, 1250mm single ledgers, 2500mm ledger beams, 1250mm guardrail frames and 2500mm guardrail frames for the second lift.



**12.** Remove the double beam rider, the upper stair handrail and the infill platform.

**13.** Install second lift stair flight.

Repeat step 6 on the erection section in this manual and continue with step 14.

**14.** Remove the 2500mm guardrail frame and fit a 1890mm guardrail frame to standard in its place.

Install clip on post and connect to opposite end of 1890mm guardrail frame.

Install upper stair handrail directly onto the clip on post and stair handrail. Tighten all securing nuts.

Install toeboards throughout the tower and tie tower as shown on page 17.

For all subsequent lifts, repeat stages 10-14.



Continue erection up to desired height as set out above. Sequent flights are carried up the stairs and 'rested' on erection platform.

## ALTERNATIVE ERECTION PROCEDURE

This erection procedure can be used to achieve first exit point heights below 1.9m.

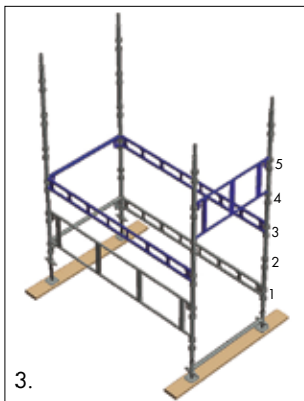
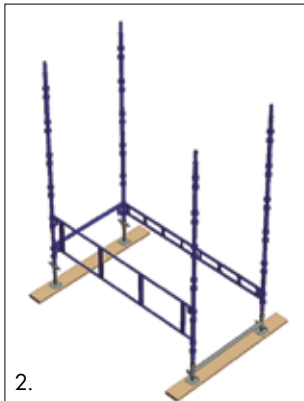
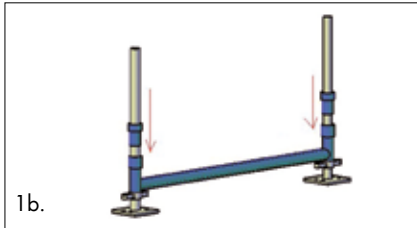
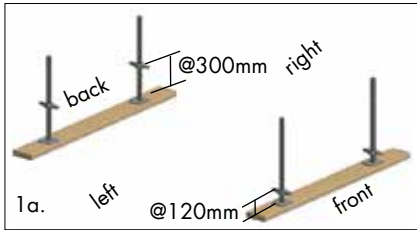

**1a.** Position the base jacks at the approximate locations of the standards. The base jacks on the front (entrance landing side) of the tower should be adjusted an approximate extension of 120mm. The base jacks on the back of the tower should be adjusted to an approximate extension of 300mm.

**1b.** On the two lower base jacks (front of tower), install the entrance transom followed by 2 compact transom spacers, one on each jack.

**2.** Install the standards on each jack. Install a 1250mm single ledger on the lowest set of pockets on the back of the tower. Install a 2500mm guardrail frame on the 2 lowest sets of pockets of the left side of the tower. Install a 2500mm ledger beam on the lowest set of pockets opposite the guardrail.

**3.** Install two ledger beams on the third set of pockets on each side of the tower. Install a single ledger at the same level.

Install a guardrail frame on the fourth and fifth set of pockets on the front standards.

Continue onto step 4 in this manual.

## Information on safety when dismantling

1. Do not throw or drop materials to the ground. This may damage the material or cause personal injury. The materials must be lowered down to the ground by means of ropes or slings or passed down by hand.
2. If intermediate ties or tie rod tubes have been installed, they must not be removed until the dismantling process reaches the level in question.
3. Always observe and comply with the regulations published by the local authorities concerned.
4. Dismantlers should always be clipped to a single ledger or ledger beam during dismantling.
5. Reference should also be made to section "Information on safety when erecting and dismantling" on page 8 in this manual.

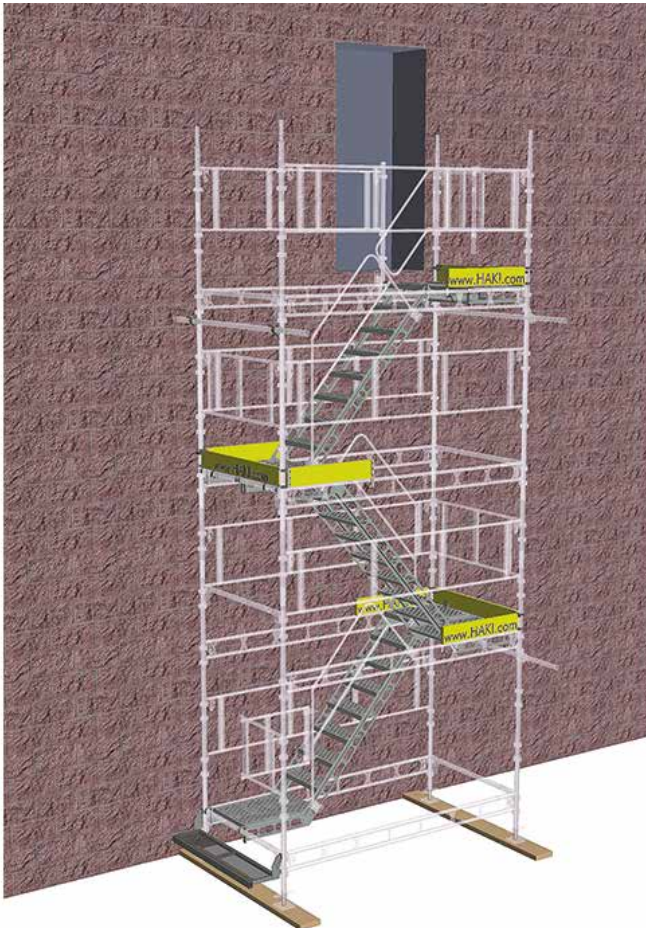

5m Compact Stair Tower

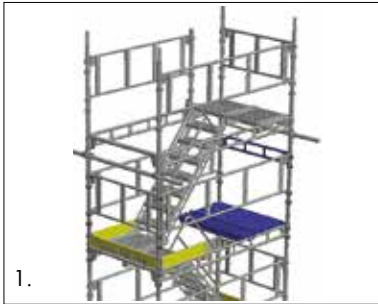

**1.** Remove all the toeboards.

From the flight, remove the upper stair handrail.

Install an erection platform plus a 1250mm steel deck below the top landing and a temporary 1250mm ledger beam using AGR tools.



**2.** From the safe working platform, remove the infill platform and the handrail.

Install a second erection platform and a 1250mm steel deck one lift underneath.



**3.** From the safe working platforms, 2 dismantlers should always remove the stair flight.

Remove the double beam rider, the clip on post and all the guardrail frames using AGR tools.



**4.** Remove lift and ties.

Repeat same dismantling procedure until dismantling is complete.

For other dismantling procedures, please contact HAKI's technical department.



### **Base jacks**

The compact stair tower is erected on base jacks of type BS, which are adjustable between 55-570 mm.

If greater adjustment is needed, lower the base jacks and connect the beams to the next group of pockets.

This means that it is always possible to adjust the standards so as to make the beams level.

### **Standards**

Standards of length 3000 and 1500 mm are normally used in the compact stair tower.

### **Beams**

The compact stair tower is erected using 2500mm ledger beams and 1250mm single ledgers as ledger and transom beams respectively.

### **Guardrails**

Stair flights must be provided with handrails on the inside. The compact stair tower must be provided with 2500mm and 1250mm guardrail frames at every half metre on the outside of the stair flight.

The compact stair tower should be provided with toeboards at all landings.

---

### **Bracing and tying in**

The compact stair tower must be anchored to the façade or equivalent at alternate landing levels (3m vertically) and top landing level from both the inside and outside standard using scaffold tube and load bearing couplers.

For other tie patterns, please contact HAKI's technical department.

**Bracing and tying in**

The permissible load on stair flights is 1.0kN/m<sup>2</sup> evenly distributed, or 1.5kN for a point load at the most onerous position.

Compact Stair Tower height [m]	Number of persons permitted
8	7
10	9
12	12
14	13
16	15
18	18
20	19
22	21
24	24
26	25
28	27
30	30
32	31
34	33
36	36
38	37
40	39
42	42
44	43
46	45
48	48
50	49

For other loads, please contact HAKI's technical department.

## Methods of erection when guardrail frame is fitted in advance



Use HAKI's advanced guardrail tool (or the aid of other guardrail fitting devices) to fit guardrail frames prior to the stair flight installation. The standards must be one metre higher than the next lift.

For other fitting devices, see HAKI Component List.



**Notes**

---

---

---

---

---

---

---

---

---

---

---

---

---

---

---

---

---

---

---

---

---

---

---

---

---

---



## HAKI Safety Checklist

### Stability

- Height & use of tower is within manufacturers recommendation's (If not alternative design in place & available)
- Ties (Correct number & Installation)
- Kentledge
- Sole pads
- Base plates/Base Jacks
- Surrounding ground conditions

### General tower

- Standards vertical within tolerances
- Ledgers & transoms level within tolerances
- Guardrail frames installed throughout
- Scaffold aligned correctly horizontally and vertically i.e. bracing correctly fitted
- All locking pins/catches engaged
- Are standards pinned (If required i.e. structure to be crane lifted, temporary roof added creating up lift, cantilevers added above last tie point, etc)

### Flights & Landings

- All flights in good condition:
  - Visual check for straightness, check complete treads for dents
  - Check all hooks are straight
  - Check all welds for any cracks or deterioration
- All flights sitting correctly on transoms (2 hooks on 2 outer transoms)
- All flights installed correctly & locking catches engaged
- All landings toe boarded

### Exits

- All exits clear & unobstructed
- Acceptable height on Entrance step (If no recommended action i.e. install double step brackets & additional step or make up entrance step with alternative materials)
- All exits guard railed off on to access platform/ into structure

### Other

- Cladding/sheeting to tower's condition



## Experience

With over 60 years experience to call on, HAKI has gained a leading reputation in its field. With its own R & D and manufacturing facilities, the company now operates throughout Europe and its equipment is in use worldwide. With all products designed and manufactured to ISO 9001:2008, and a comprehensive training and support infrastructure, you can rely on HAKI for support.



## Training

The Company's dedicated Training Centre is equipped with the full range of HAKI products where a comprehensive choice of courses is offered. With the benefit of this training, all users of HAKI products can be assured that the equipment is being employed safely and effectively.



## Support

From computerised estimating facilities to on site assessment and project back up, HAKI is with its customers every step of the way. Working with HAKI means far more than just proven equipment, it means working with people who understand the scaffolding industry. Whatever the project, the company is committed to ensuring every user enjoys the full benefits associated with the use of HAKI - maximising the savings, profitability, and above all, SAFETY.

## Health and Safety at Work Act, 1974

HAKI equipment is designed to meet the requirements of the above Act, Section 6.

It is also the customer's responsibility to comply with the requirements of this Act, particularly to use the equipment in accordance with current codes of practice and in ensuring that components are in good working condition prior to each use.

We are able to provide assistance and advice on matters relating to safe and proper use of HAKI equipment.

